

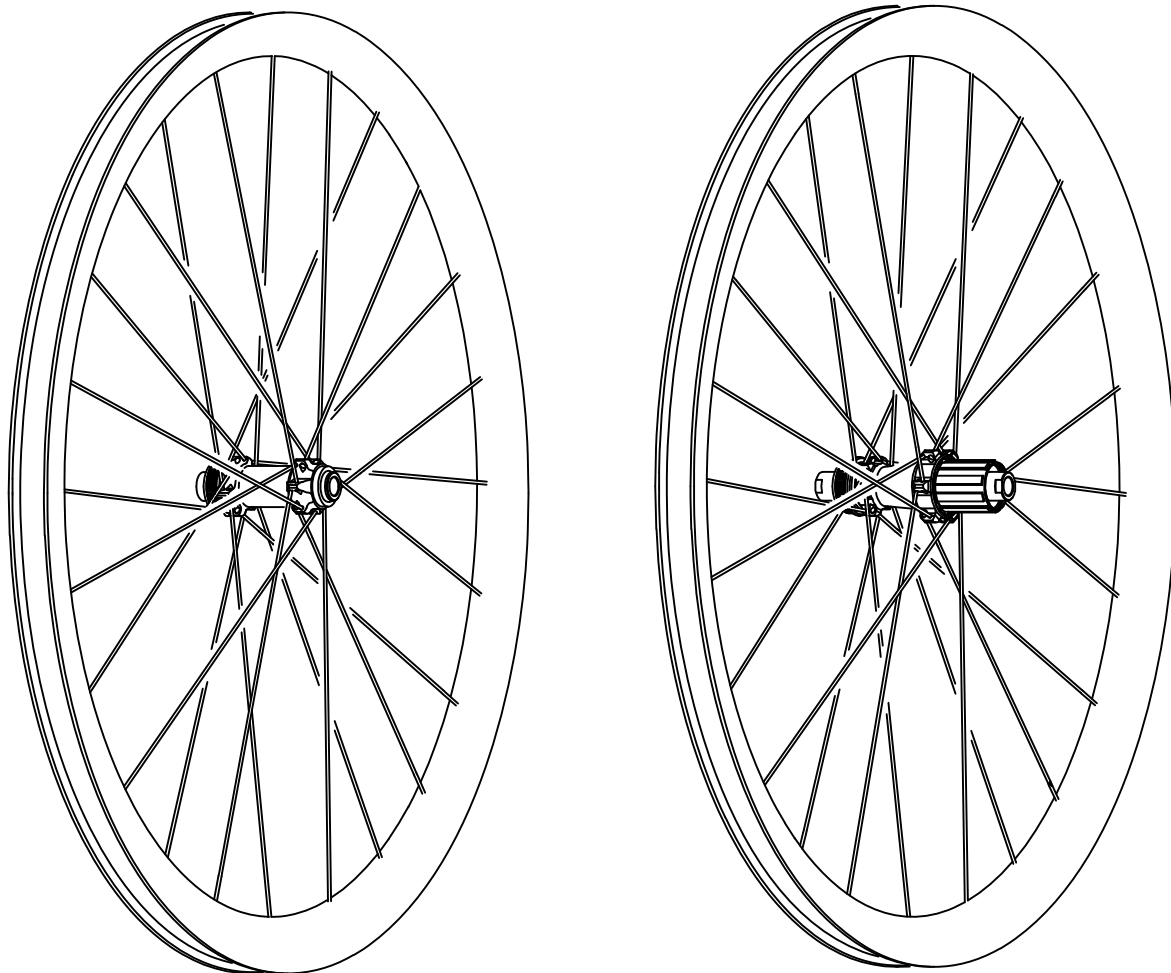

C25AD

PRIME Alloy Clincher

DISC BRAKE ALLROAD WHEELSET



SPECIFICATION

RIM				HUB	SPOKE / NIPPLE	CASSETTE BODY	WHEEL MAXIMUM
Profile Depth	Internal Width	External Max Width	Recommended Tyre Size	D1 Hubset F-24H R-24H PREMIUM Bearing	Pillar WING 22 Black Spoke Alloy External Black Nipple	Shi & SRAM or Campy 10-11S - or - SRAM XDR	Inflation Pressure 100psi (700x25c) Rider Weight 100kg
25mm	20mm	24mm	700x25c -700x32c				

WARNING

1. Use only TOKEN brand carbon-rim specified brake pads on rims with carbon fiber brake track. Use other brake pads could degrade braking performance and may lead to unwanted character such as noise and heat accumulation, as well as serious injury of rider.
2. Over tensioning spokes and exceeding maximum inflation pressure could cause unseen damage. Note that overly inflated tyres don't necessarily have lower rolling resistance, and may have inferior traction!
3. Discontinue use of rim immediately if the brake track is worn, deformed (carbon) or the wear indication dots disappear (alloy).
4. Mounting clincher tyres on tubeless-ready rims could take more effort than on regular rims. Take great care not to damage any part of the rim with tyre lever! Applying mild soap water or tyre sealant on rim and tyre bead could make tyre installation easier.
5. Make sure your tyre-and-wheel combination meets ISO 4210-6 Safety Requirement regulation - there should always be a clearance no less than 4mm between the tyre and the frame, as well as other components such as brake caliper.
6. Failure to follow the conditions listed above may result in 2-year warranty being voided. Contact your local dealer or see the TOKEN website for details. -www.tokenproducts.com-

HUBS

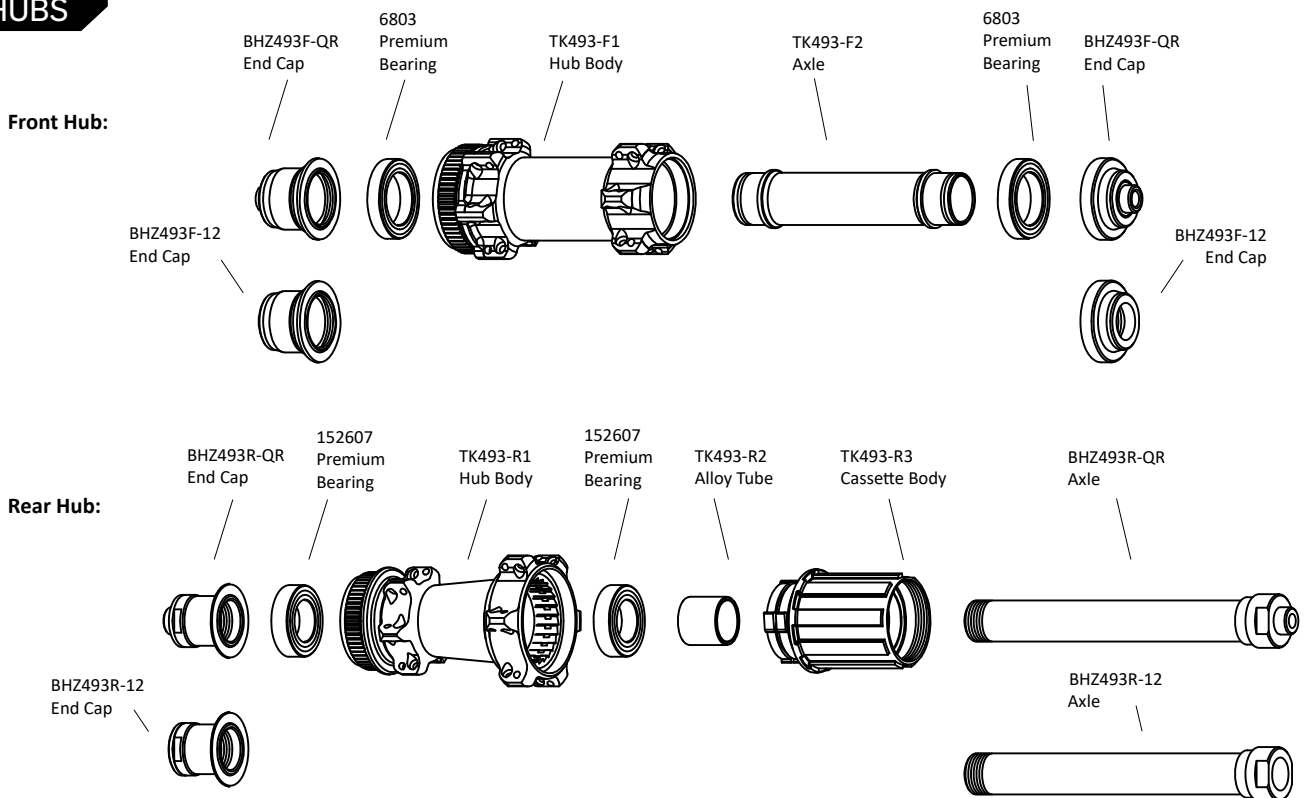

WHEEL BUILDING

RIM

BEARING

Spoke Information		Tension (kgf)	Size	Length (mm)	ERD (mm)	Front	Rear
Front	Drive Side (RH)	80~100	14G	296	591.5mm	6803 * 2	152607 * 4
	Non-Drive Side (LH)	100~120	14G	294			
Rear	Drive Side (RH)	110~130	14G	294			
	Non-Drive Side (LH)	70~90	14G	296			